

MLW 9Y

- Maximum height 9 m
- Hot dip galvanized telescopic mast hydraulically raised
- Noise pressure 58dB[A] approx. @ 7 meters and 86 LWA
- Biodegradable oil in hydraulic system
- Bunded tank to avoid fuel spillage on the ground. Engine fluids banded 120%
- Hydraulic lifting system with manual release
- 360° mast rotation by hand
- Certified wind proof up to 80Km/h
- 4 floodlights 1000W metal halide or 6 floodlights 1000W halogen
- Forklift pockets
- Fork pockets & 4-point anti-spin lifting eyes
- More than 60 hours of running time



Main applications:

- Events / Shows
- Road works
- Construction site
- Civil protection
- Industrial application
- Rental use

GENERATING SET
MLW 9Y
DIESEL ENGINE

BRAND		YANMAR
MODEL		3 TNV 76
COOLING SYSTEM	Type	Water
SPEED	rpm	1500
DISPLACEMENT	cc	1116
CYLINDERS & DISPOSITION	n° disp.	3
ASPIRATION	Type	Natural
ENGINE POWER LTP	kW	9
SPECIFIC FUEL CONSUMPTION @ 75% PRP	L/h	2.03
SPECIFIC FUEL CONSUMPTION @ 100% PRP	L/h	2.70
ENGINE GOVERNOR (Standard)	Type	Mechanical
ELECTRICAL SYSTEM (DC)	Volt	12

TECHNICAL DATA

NOMINAL POWER	kVA	9
VOLTAGE	Volt	230
PHASES	N	Single phase
FREQUENCY	Hz	50
POWER FACTOR	Cos Φ	0.9
TANK CAPACITY	L	120
RUNNING-TIME (Lights only)	Hrs	60.3
TRAILER TYPES		Slow trailer (max 25km/h) / Road trailer
OPERATING DIMENSIONS (LxWxh)	mm	2730 x 1850 x 9000
WEIGHT (Dry)	Kg	970

SYNCHRONOUS ALTERNATOR

LINZ		E1C135D
NOMINAL POWER	kVA	9
INSULATION	Class	F
MECHANICAL DEGREE OF PROTECTION	Type	IP21
VOLTAGE REGULATION	Type / Model	Compound

LAMPS

LIGHT POWER	Watt	4 x 1000
LIGHTS	Type	Metal Halide
TOTAL LUMINOUS FLUX	Lm	360.000
MAST ELEVATION	Type	Hydraulic



MCP - Manual control panel

ENGINE PROTECTION

- Low Oil Pressure Shutdown
- High Engine Temperature Shutdown

COMMANDS AND OTHERS

- Start/stop with key switch
- Four (4) individual circuit breakers for each lamp

PROTECTION WITH SHUTDOWN

- Engine protection: low oil pressure, high engine temperature
- Main circuit breaker

OUTPUT

- 16A 2P+T 230V outlet sockets



TRAILERS

SITE TRAILER

- Single axle without brakes
- Forklift pockets
- Four stabilizers with manual rotation
- Ball hitch type or DIN coupler eyes



ROAD TRAILER

- Single axle with brakes and rear lights
- Forklift pockets
- Four stabilizers with manual rotation
- Fix or adjustable draw bar
- Large selection of coupling eye

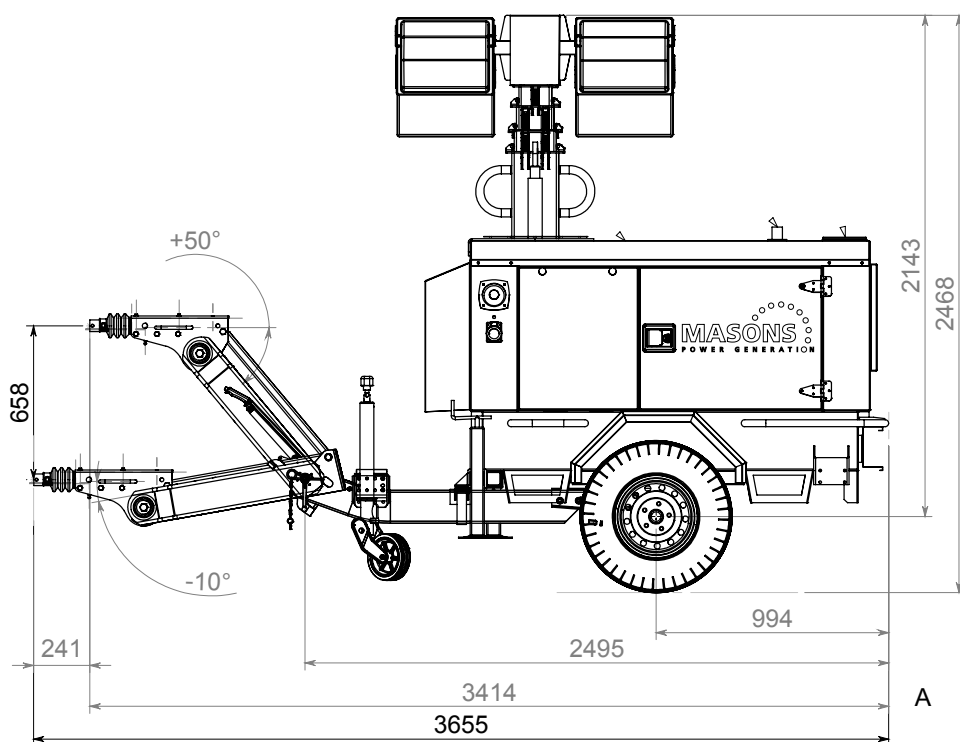
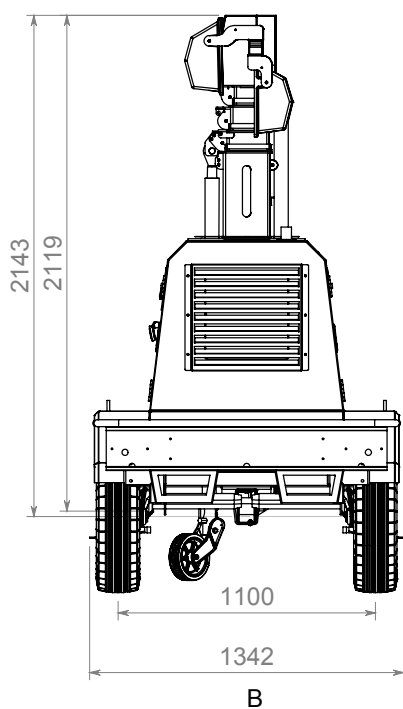



www.masonsgenerators.com

MASONS DISTRIBUTOR IN YOUR AREA IS:

PR MIDDLE EAST FZE

1206 JAFZA View 18, P.O. Box 262478 - Jebel Ali Free Zone - South 1, Dubai
Tel.: +971 4 8865275 - Fax: +971 4 8865276